



RS-325

ROTO-MIXER® RECLAIMER/STABILIZER

S P E C I F I C A T I O N S



- *Multi-Purpose Road Reclaimer Soil Stabilizer*
- *4 Wheel Drive With Traction Control*
- *4 Wheel Steering With 4 Steering Modes*
- *High Travel Speed*
- *Excellent Visibility*
- *Wide Variety of Cutter Options*

The RS-325 is designed to efficiently perform a variety of jobs from asphalt road reclamation to soil stabilization.

The wide range of cutters available offers contractors full utilization of the machine and extends the limit of their operations.

The rear-mounted cutter lets the operator back up very close to walls or other barriers.

The high-mounted rear access door opens for convenient cutter inspection and service.

The hinged side doors allow easy access to the entire engine and transmission components.

The RS-325 is the most maneuverable, versatile and productive machine in its class.

RS-325

SPECIFICATIONS

DIMENSIONS:

	U.S. Standard	Metric
Length	23'6"	7163 mm
Width	7'4"	2235 mm
Height	9'10"	2997 mm
Weight	31,200 lbs.	14180 kg
Wheelbase	7'8"	2337 mm
Ground Clearance	16"	407 mm

ENGINE:

	Cummins	
Make	Cummins	
Type	Turbocharged Diesel	
Model	M 11	
Horsepower	330	246 kW
Electrical	12 Volts	

DRIVE SYSTEM:

	4 Wheel	
Drive	4 Wheel	
Type	Hydrostatic/Forward & Reverse	
Speed Ranges:		
Working:	1st Range	0-200 fpm
0-61 m/min	2nd Range	0-360 fpm
0-110 m/min		
Traveling:	1st Range	0-6.8 mph
0-11 km/hr	2nd Range	0-12.5 mph
0-20 km/hr		
Tires:		
Type:	12 Ply Pneumatic	
Size:	17.5-25	
Wheel	13x25	
Steering:		
Type	Hydraulic Power	
Mode 1	Front Only	
Mode 2	Rear Only	
Mode 3	Front & Rear Same (Crab)	
Mode 4	Coordinated Front & Rear (Cramp)	

BRAKE SYSTEM:

Parking/Emergency Service	Hydraulic Disc Spring Applied
	Hydrostatic/Dynamic

CAPACITIES:

Diesel Fuel	135 gallons	511 liters
Hydraulic Oil	41 gallons	155 liters
Cooling System	10 gallons	38 liters

CUTTER SYSTEM:

Power Transmission	High Efficiency Hydrostatic, Closed Loop
Drive Type	Planetary Gear Box Reduction
Standard Width	75" 1524 mm
Standard Depth	16" 406 mm
Optional Depth	20" 508 mm

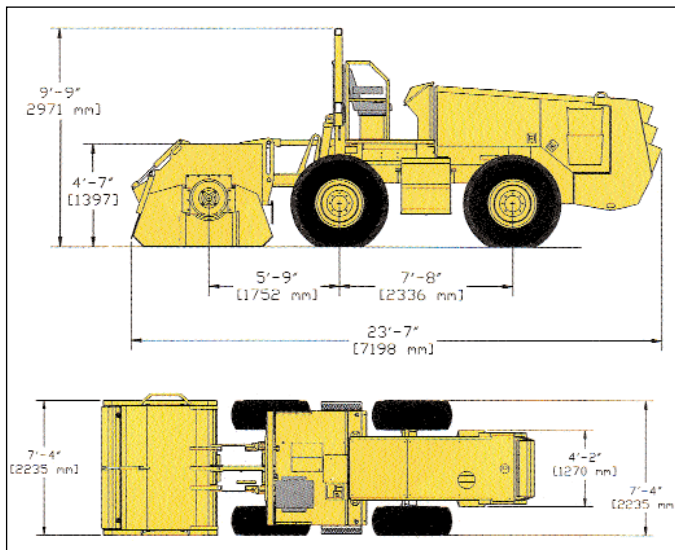

Cutter Speeds:

Low	120 RPM
High	175 RPM

Cutter Type:

Standard	Heavy Duty 6'3" Reclamation Pulverizer Cutter with Doweled Tool Holders
Optional	Heavy Duty Mixing/Soil Stabilizer Cutter System Heavy Duty Multi Purpose Cutters Deep Cut Saws and Trenching Wheels Quick Change System Available On All Cutters

CUTTER CONTROLS:

Hydraulic Raise & Lower	Cutter Depth Indicator
-------------------------	------------------------

INSTRUMENTATION:

Engine Oil Pressure	Fuel Gauge
Engine Temperature	Hydraulic Oil Temperature
Engine Voltmeter	Propel Pressure Gauge
Engine Hourmeter	Cutter Pressure Gauge
Tachometer	Charge Pressure Gauges
Hi Temp/Low Oil Light	

STANDARD FEATURES:

Deluxe Operator Seat	Low Oil/High Temp Engine
Roll Over Protection Structure	Shut Down
Vandalism Cover	Reverse Alarm
Strobe Light	Tie Down Loops
Rubber Mount Operator Station	Rubber Drum Skirting
	Flush Cut Left, Flush Cut Right Capability

OPTIONAL EQUIPMENT:

Work Lights	Non Contact Grade Sensors
Water System	

Note: All specifications subject to change without notice or obligation. Performance may vary depending on job conditions.



CMI TEREX CORPORATION

PO Box 1985 • Oklahoma City, Oklahoma 73101-1985 • USA
Phone (405) 787-6020 • Fax (405) 491-2417 WEBSITE: www.cmicorp.com